



Instanta G2 InstaTap

Commercial Boiling 50 litre Polished Stainless Steel Double Font

BOILING



2 fonts included:

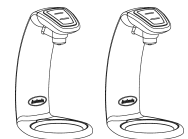

Also available in:



MATT BLACK

Product code: I2CB50BD

Actual product may vary slightly depending on functionality. The image shown is a representation only.

Features and benefits

Enhanced hygiene

Antimicrobial steritouch keypad that reduces 99.9% of surface bacteria, perfect for maintaining hygiene.

Smooth water flow

Dispenses a smooth water flow to minimise spluttering and steam.

Choice of dispense

There are three options available: free pour and 2 measured dispense.

Choice of design

Available in 2 heights and 2 finishes.

Model	Capacity	Heat up time (minutes)	Rapid draw off (litres)	Rapid draw off (cups)*	Boiling cups per hour*	Nominal power rating kW @ 230V	Command centre dimensions W x D x H
I2CB50D	50 Litres	42 @ 6.75kW 64 @ 4.5kW	50	300	378 @ 6.75kW 252 @ 4.5kW	6.75kW 4.5kW	560mm x 510mm x 600mm

*Cups measured at 167ml

Product detail

Specification type

Product code	I2CB50D
Product name	InstaTap G2 Commercial Boiling 50ltr polished stainless steel double font

Capacity, weights & dimensions

Water functions	Boiling
Boiling capacity	378 Cups per hour @ 6.75kW or 252 Cups per hour @ 4.5kW (default temperature setting at 96 °C)
Unit dimension (W x D x H)	560mm x 510mm x 600mm
Product weight - empty / full	26kg / 70kg

Plumbing

Wholesome water inlet supply required	Cold Feed
Supply pressure range	2 - 5 bar
Supply connection	1 x isolated 3/4" BSP BSP fitting (Install rail 15mm)
Installation	Must comply with current water supply regulations

Electrical

Command centre power rating	4.5kW (default) or 6.75kW @ 220-240V
Voltage supply	20amps (4.5kW) or 30amps (6.75kW)
Power supply requirements	Single-phase supply via an isolation switch
Cable length	1.7m fitted
Installation	Must comply with current IEEE regulations

Font

Style	Standard
Finish	Polished stainless steel
Fonts included	2
Dimensions (W x D x H)	150mm x 197mm x 275mm
Tap font clearance	195mm
Disability options	No
Packed Dimensions (W x D x H)	400mm x 315mm x 275mm (2 x boxes)
Packed weight	9.2kg (2 x 4.6kg boxes)

Command Centre

Factory temperature boiling	96°C
Heat up time	64 mins (4.5kW) or 42 mins (6.75kW)
Stand by power loss (Idle over 24hrs)	1.5 kW/h
Wholesome water supply requirements	Cold Feed
Tank material	Stainless steel
Packed Dimensions (W x D x H)	620mm x 620mm x 665mm
Packed weight	28kg

Font installation

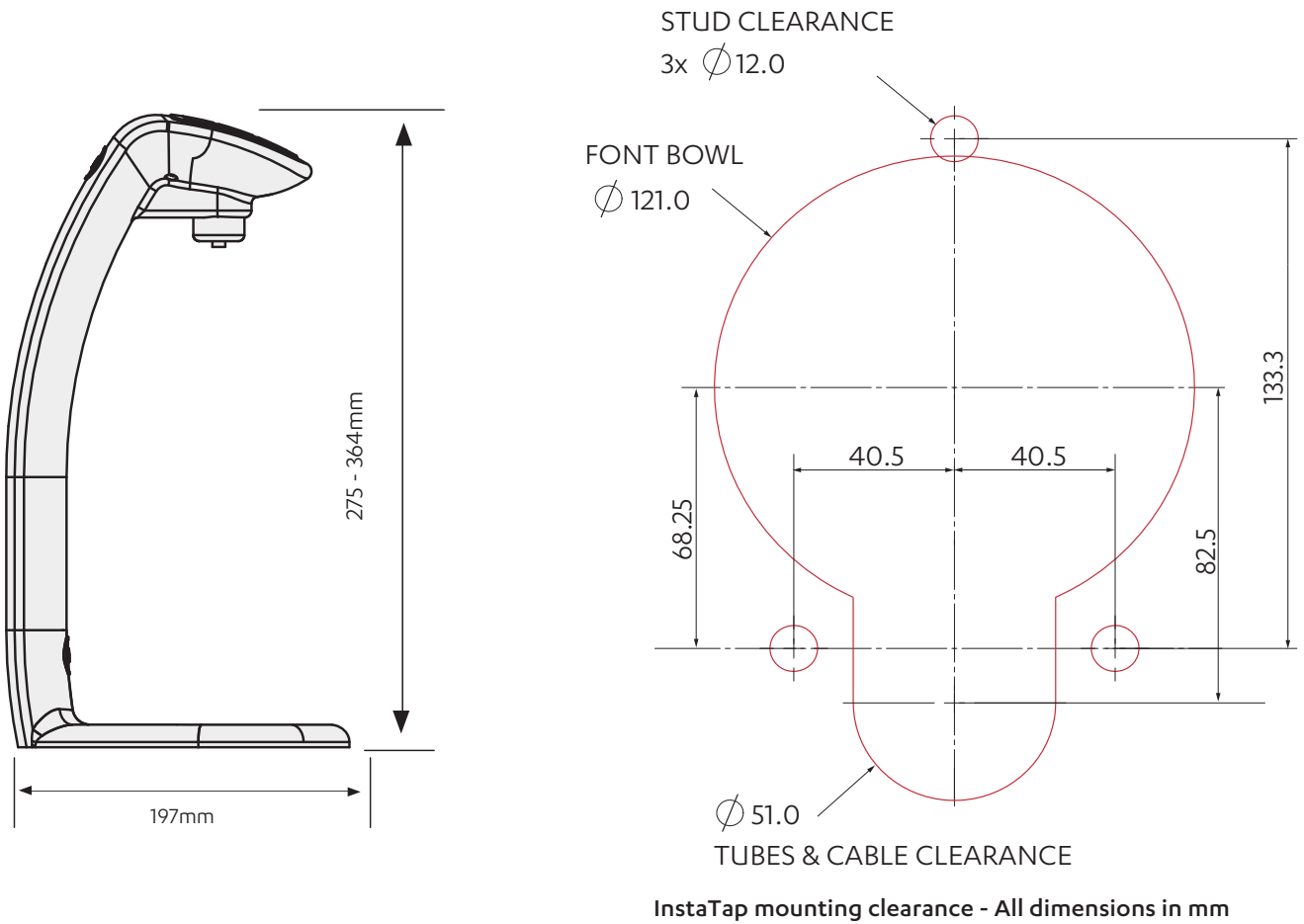

Under-counter unit installation

Clearance space required
for under counter unit

